

LECTURE NOTEON

# POWER ELECTRONICS (TH.5)

5<sup>TH</sup> SEMESTER



PREPARED BY

**Er. RUPAK KUMAR  
SAHOO**

( Sr. LECTURE) DEPARTMENT OF ELECTRICAL ENGG.  
G.I.E.T (POLYTECHNIC),JAGATPUR,CUTTACK,ODISHA

# POWER ELECTRONICS

The control of electric motor drives requires control of electric power. Power electronics have eased the concept of power control. Power electronics signifies the word power electronics and control or we can say the electronic that deal with power equipment for power control.

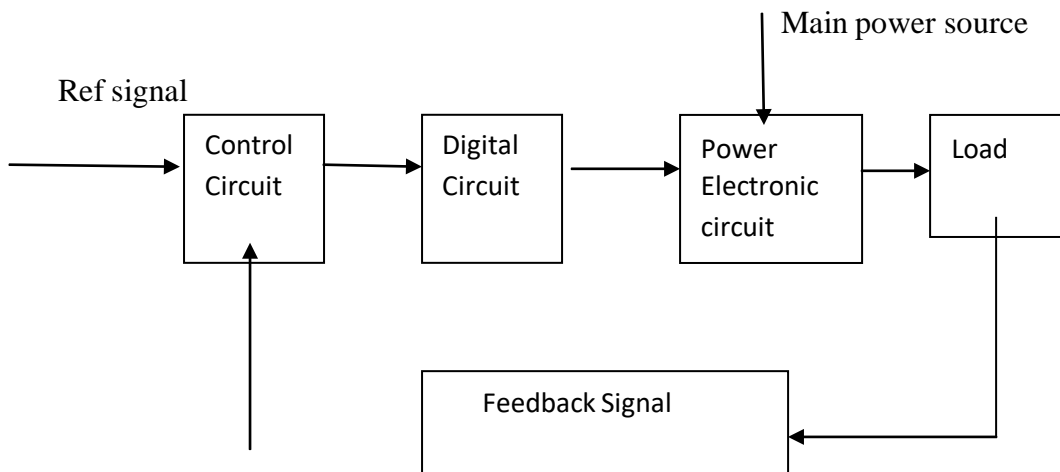

Power electronics based on the switching of power semiconductor devices. With the development of power semiconductor technology, the power handling capabilities and switching speed of power devices have been improved tremendously.

## Power Semiconductor Devices

1. Power diodes
2. Transistors
3. Thyristors

Thyristor is a four layer three junction pnpn semiconductor switching device. It has 3 terminals these are anode, cathode and gate. SCRs are solid state device, so they are compact, possess high reliability and have low loss.

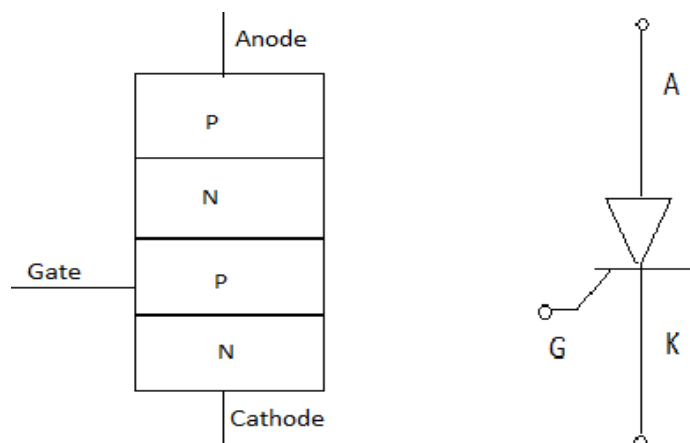

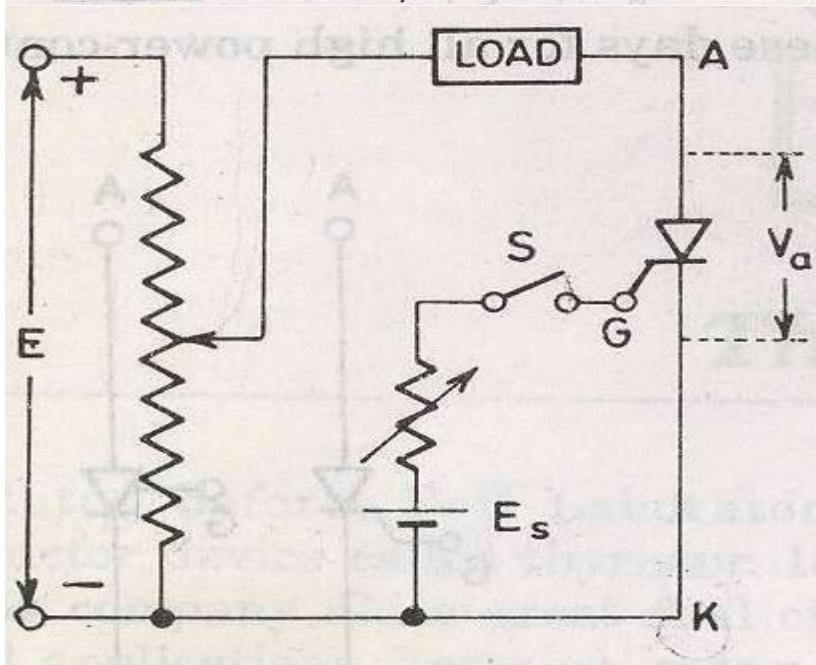
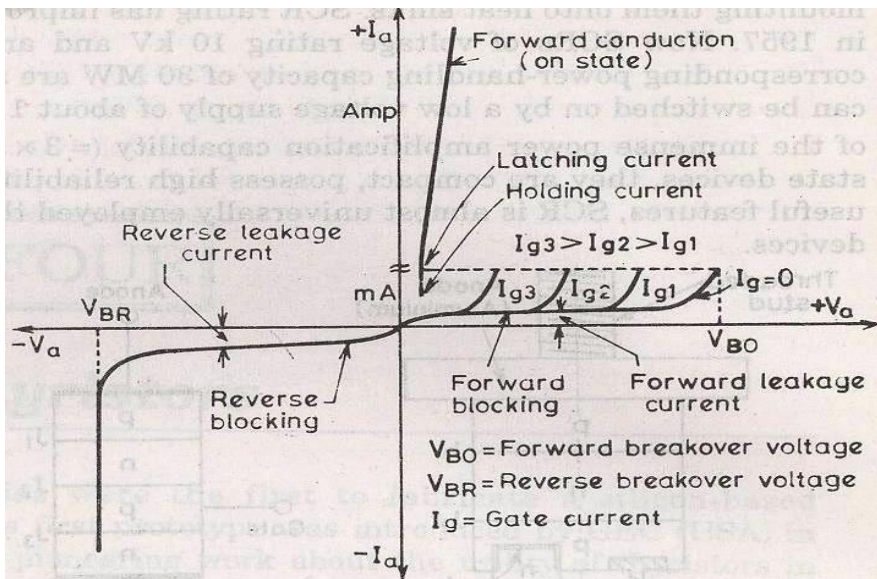

**(V-I CHARACTERISTIC OF SCR)**

$V_{BO}$  = Forward breakover voltage

$V_{BR}$  = Reverse breakover voltage

$I_g$  = Gate current

$V_a$  = Anode voltage across the thyristor terminal A, K.

$I_a$  = Anode current

It can be inferred from the static V-I characteristic of SCR. SCR have 3 modes of operation:

1. Reverse blocking mode
2. Forward blocking mode ( off state)
3. Forward conduction mode (on state)

### 1. Reverse Blocking Mode

When cathode of the thyristor is made positive with respect to anode with switch open thyristor is reverse biased. Junctions  $J_1$  and  $J_2$  are reverse biased where junction  $J_2$  is forward biased. The device behaves as if two diodes are connected in series with reverse voltage applied across them.

- A small leakage current of the order of few mA only flows. As the thyristor is reverse biased and in blocking mode. It is called as acting in reverse blocking mode of operation.
- Now if the reverse voltage is increased, at a critical breakdown level called reverse breakdown voltage  $V_{BR}$ , an avalanche occurs at  $J_1$  and  $J_3$  and the reverse current increases rapidly. As a large current associated with  $V_{BR}$  and hence more losses to the SCR.

### 2. Forward Blocking Mode

When anode is positive with respect to cathode, with gate circuit open, thyristor is said to be forward biased.

Thus junction  $J_1$  and  $J_3$  are forward biased and  $J_2$  is reverse biased. As the forward voltage is increases junction  $J_2$  will have an avalanche breakdown at a voltage called forward breakover voltage  $V_{BO}$ . When forward voltage is less than  $V_{BO}$  thyristor offers high impedance. Thus a thyristor acts as an open switch in forward blocking mode.

### 3. Forward Conduction Mode

Here thyristor conducts current from anode to cathode with a very small voltage drop across it. So a thyristor can be brought from forward blocking mode to forward conducting mode:

1. By exceeding the forward breakover voltage.
2. By applying a gate pulse between gate and cathode.

During forward conduction mode of operation thyristor is in on state and behave like a close switch. Voltage drop is of the order of 1 to 2mV. This small voltage drop is due to ohmic drop across the four layers of the device.

### Different turn ON methods for SCR

1. Forward voltage triggering
2. Gate triggering
3.  $\frac{dv}{dt}$  triggering
4. Light triggering
5. Temperature triggering

## 1. Forward voltage triggering

A forward voltage is applied between anode and cathode with gate circuit open.

- Junction  $J_1$  and  $J_3$  is forward biased.
- Junction  $J_2$  is reverse biased.
- As the anode to cathode voltage is increased breakdown of the reverse biased junction  $J_2$  occurs. This is known as avalanche breakdown and the voltage at which this phenomena occurs is called forward breakover voltage.
- The conduction of current continues even if the anode cathode voltage reduces below  $V_{BO}$  till  $I_a$  will not go below  $I_h$ . Where  $I_h$  is the holding current for the thyristor.

## 2. Gate triggering

This is the simplest, reliable and efficient method of firing the forward biased SCRs. First SCR is forward biased. Then a positive gate voltage is applied between gate and cathode. In practice the transition from OFF state to ON state by exceeding  $V_{BO}$  is never employed as it may destroy the device. The magnitude of  $V_{BO}$ , so forward breakover voltage is taken as final voltage rating of the device during the design of SCR application.

First step is to choose a thyristor with forward breakover voltage (say 800V) higher than the normal working voltage. The benefit is that the thyristor will be in blocking state with normal working voltage applied across the anode and cathode with gate open. When we require the turning ON of a SCR a positive gate voltage between gate and cathode is applied. The point to be noted that cathode n-layer is heavily doped as compared to gate p-layer. So when gate supply is given between gate and cathode gate p-layer is flooded with electron from cathode n-layer. Now the thyristor is forward biased, so some of these electron reach junction  $J_2$ . As a result width of  $J_2$  breaks down or conduction at  $J_2$  occur at a voltage less than  $V_{BO}$ . As  $I_g$  increases  $V_{BO}$  reduces which decreases then turn ON time. Another important point is duration for which the gate current is applied should be more then turn ON time.

## 3. dv/dt triggering

When SCR is forward biased, junction  $J_1$  and  $J_3$  are forward biased and junction  $J_2$  is reversed biased so it behaves as if an insulator is place between two conducting plate. Here  $J_1$  and  $J_3$  acts as a conducting plate and  $J_2$  acts as an insulator.  $J_2$  is known as junction capacitor. So if we increase the rate of change of forward voltage instead of increasing the magnitude of voltage. Junction  $J_2$  breaks and starts conducting. A high value of changing current may damage the SCR. So SCR may be protected from high  $\frac{dv}{dt}$ .

#### **4. Light triggering**

First a new recess niche is made in the inner p-layer. When this recess is irradiated, then free charge carriers (electron and hole) are generated. Now if the intensity is increased above a certain value then it leads to turn ON of SCR. Such SCR are known as Light activated SCR (LASCR).

#### **5. Temperature triggering**

During forward biased,  $J_2$  is reverse biased so a leakage forward current always associated with SCR. Now as we know the leakage current is temperature dependant, so if we increase the temperature the leakage current will also increase and heat dissipation of junction

$J_2$  occurs. When this heat reaches a sufficient value  $J_2$  will break and conduction starts.  
Disadvantages

### Latching current

The latching current may be defined as the minimum value of anode current which must attain during turn ON process to maintain conduction even if gate signal is removed.

### Holding current

It is the minimum value of anode current below which if it falls, the SCR will turn OFF.

### **Switching characteristics of thyristors**

The time variation of voltage across the thyristor and current through it during turn on and turn off process gives the dynamic or switching characteristic of SCR.

### **Switching characteristic during turn on Turn on time**

It is the time during which it changes from forward blocking state to ON state. Total turn on time is divided into 3 intervals:

1. Delay time
2. Rise time
3. Spread time

### **Delay time**

If  $I_g$  and  $I_a$  represent the final value of gate current and anode current. Then the delay time can be explained as time during which the gate current attains  $0.9 I_g$  to the instant anode current reaches  $0.1 I_g$  or the anode current rises from forward leakage current to  $0.1 I_a$ .

1. Gate current  $0.9 I_g$  to  $0.1 I_a$ .
2. Anode voltage falls from  $V_a$  to  $0.9V_a$ .
3. Anode current rises from forward leakage current to  $0.1 I_a$ .

hot spot and may cause thermal run away of the device. This triggering cannot be controlled easily.

It is very costly as protection is costly.

### **3. Light triggering**

First a new recess niche is made in the inner p-layer. When this recess is irradiated, then free charge carriers (electron and hole) are generated. Now if the intensity is increased above a certain value then it leads to turn ON of SCR. Such SCR are known as Light activated SCR (LASCR).

*Some definitions:*

#### **Latching current**

The latching current may be defined as the minimum value of anode current which at must attain during turn ON process to maintain conduction even if gate signal is removed.

#### **Holding current**

It is the minimum value of anode current below which if it falls, the SCR will turn OFF.

### **Switching characteristics of thyristors**

The time variation of voltage across the thyristor and current through it during turn on and turn off process gives the dynamic or switching characteristic of SCR.

#### **Switching characteristic during turn on**

##### **Turn on time**

It is the time during which it changes from forward blocking state to ON state. Total turn on time is divided into 3 intervals:

1. Delay time
2. Rise time
3. Spread time

##### **Delay time**

If  $I_g$  and  $I_a$  represent the final value of gate current and anode current. Then the delay time can be explained as time during which the gate current attains  $0.9 I_g$  to the instant anode current reaches  $0.1 I_g$  or the anode current rises from forward leakage current to  $0.1 I_a$ .

1. Gate current  $0.9 I_g$  to  $0.1 I_a$ .
2. Anode voltage falls from  $V_a$  to  $0.9V_a$ .
3. Anode current rises from forward leakage current to  $0.1 I_a$ .



### **Rise time ( $t_r$ )**

Time during which

1. Anode current rises from  $0.1 I_a$  to  $0.9 I_a$
2. Forward blocking voltage falls from  $0.9V_a$  to  $0.1V_a$ .  $V_a$  is the initial forward blocking voltage.

### **Spread time ( $t_p$ )**

1. Time taken by the anode current to rise from  $0.9I_a$  to  $I_a$ .

Time for the forward voltage to fall from  $0.1V_o$  to on state voltage drop of 1 to 1.5V. During turn on, SCR is considered to be a charge controlled device. A certain amount of charge is injected in the gate region to begin conduction. So higher the magnitude of gate current it requires less time to inject the charges. Thus turn on time is reduced by using large magnitude of gate current.

## **THYRISTOR PROTECTION**

### *OVER VOLTAGE PROTECTION*

Over voltage occurring during the switching operation causes the failure of SCR.

### **INTERNAL OVERVOLTAGE**

It is due to the operating condition of SCR.

During the commutation of SCR, when the anode current decays to zero anode current reverses due to stored charges. First the reverse current rises to peak value, then reverse current reduces abruptly with large  $di/dt$ . During series inductance of SCR large transient large voltage i.e  $L di/dt$  is generated.

## EXTERNAL OVER VOLTAGE

This is due to external supply and load condition. This is because of

1. The interruption of current flow in an inductive circuit.
2. Lightning strokes on the lines feeding the thyristor systems.

Suppose a SCR converter is fed from a transformer, voltage transient occur when transformer primary will energise or de-energised.

This overvoltages cause random turn ON of a SCR.

The effect of overvoltage is minimized using

1. RC circuits

Non linear resistor called voltage clamping device

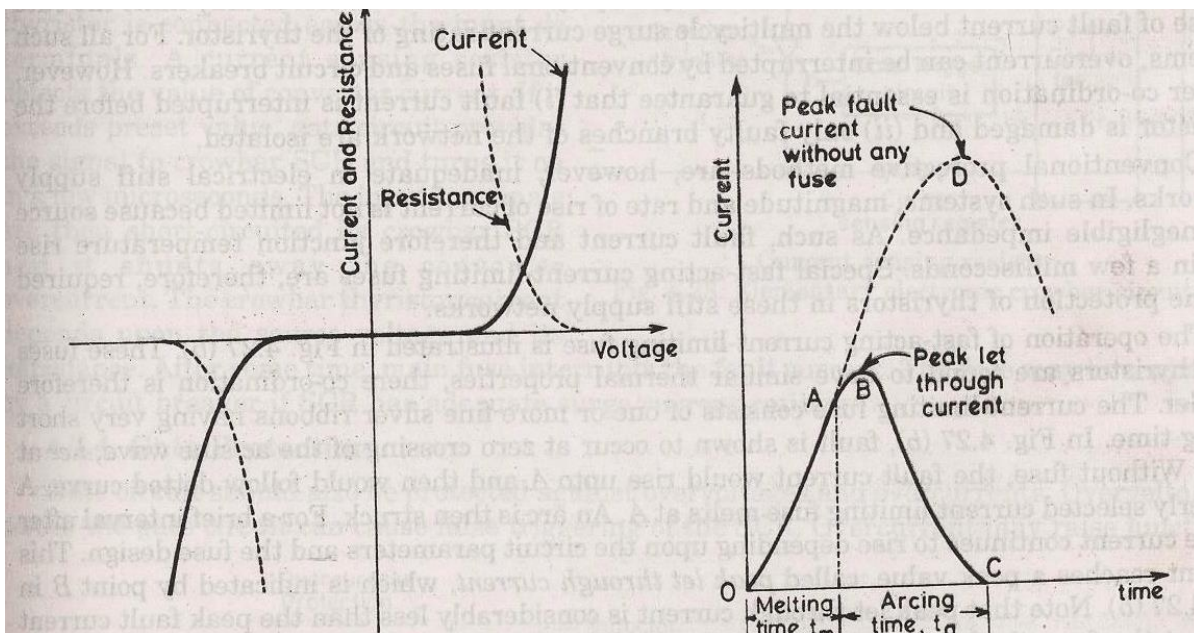

Voltage clamping device is a non linear resistor. It is connected between cathode and anode of SCR. The resistance of voltage clamping device decreases with increasing voltages. During normal working condition Voltage clamping (V.C) device has high resistance, drawing only leakage current. When voltage surge appears voltage clamping device offers a low resistance and it create a virtual short circuit across the SCR. Hence voltage across SCR is clamped to a safe value.

When surge condition over voltage clamping device returns to high resistance state.

e.g. of voltage clamping device

- 1.Seleniumthyrector diodes
- 2.Metal Oxide varistors
- 3.Avalanche diode supressors

#### OVER CURRENT PROTECTION

Long duration operation of SCR, during over current causes the

1.junction temp. of SCR to rise above the rated value,causing permanent damage to device.

SCR is protected from overcurrent by using

- 1.Circuit breakers
- 2.Fast acting fuses

Proper co-ordination is essential because

- 1..fault current has to be interrupted before SCR gets damaged.
- 2.only faulty branches of the network has to be replaced.

In stiff supply network,source has negligible impedance.So in such systemthe magnitude and rate of rise of current is not limited.Fault current hence junction temp rises in a few milliseconds.

#### POINTS TO BE NOTED-

1. Proper coordination between fast acting fuse and thyristor is essential.
2. The fuse is always rated to carry marginal overload current over definite period.
3. The peak let through current through SCR must be less than sub cycle rating of the SCR.
4. The voltage across the fuse during arcing time is called arcing or recovery voltage and is equal to sum of the source voltage and emf induced in the circuit inductance during arcing time.
5. On abrupt interruption of fuse current, induce emf would be high, which results in high arcing voltage.

#### Circuit Breaker (C.B)

C.B. has long tripping time. So it is used for protecting the device against continuous overload current or against the surge current for long duration. In order that fuse protects the thyristor realiably the  $I^2t$  rating of fuse current must be less than that of SCR.

#### ELECTRONIC CROWBAR PROTECTION

For overcurrent protection of power converter using SCR, electronic crowbar are used. It provide rapid isolation of power converter before any damage occurs.

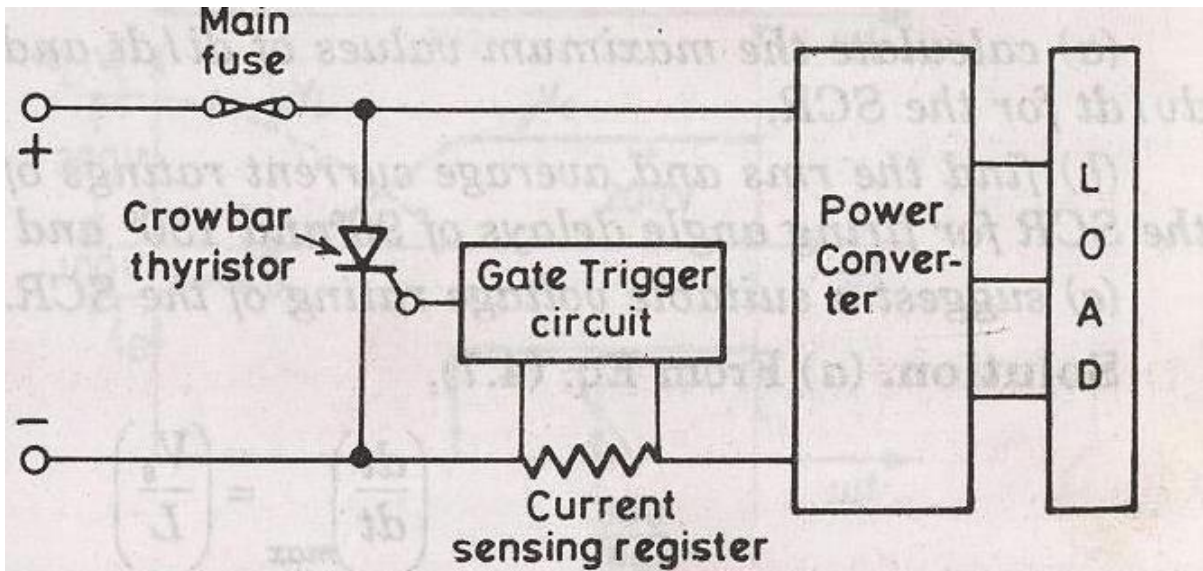

#### HEAT PROTECTION-

To protect the SCR

1. From the local spots
2. Temp rise

SCRs are mounted over heat sinks.

#### GATE PROTECTION

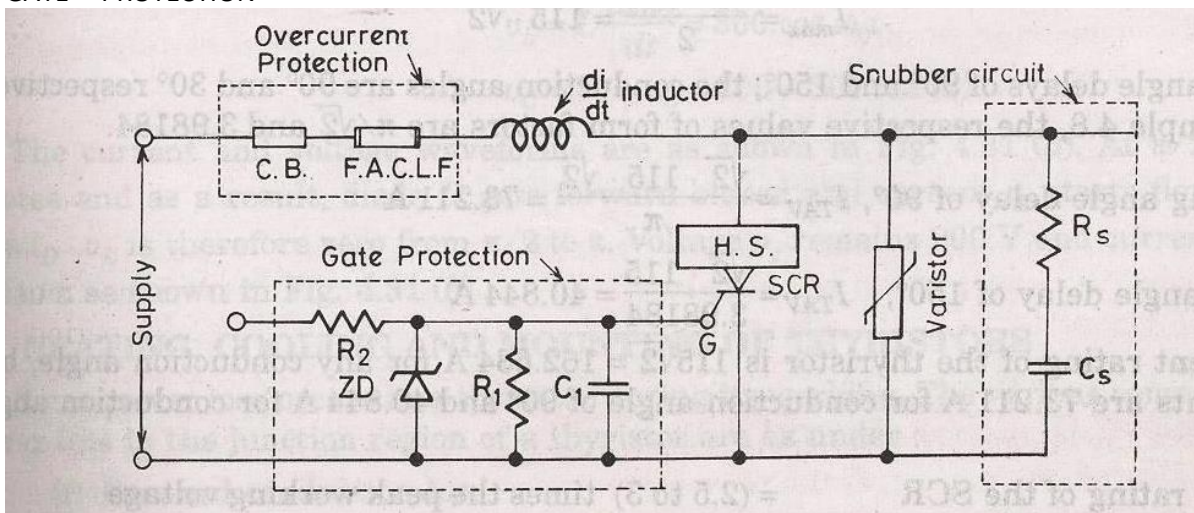

Gate circuit should also be protected from

1. Overvoltages
2. Overcurrents

Overvoltage across the gate circuit causes the false triggering of SCR

Overcurrent raise the junction temperature. Overvoltage protection is by zener diode across the circuit.

gate